

Klip-lok roof solar mounting system

# installation manual

For LYSAGHT KLIP-LOK 406 KLIP-LOK CLASSIC 700  
KLIP-LOK 700 HI-STRENGTH flush mount with rail and  
tilt mount with adjustable legs Planning and Installation  
Complying with AS/NZS1170.2:2011 AMDT 2-2012

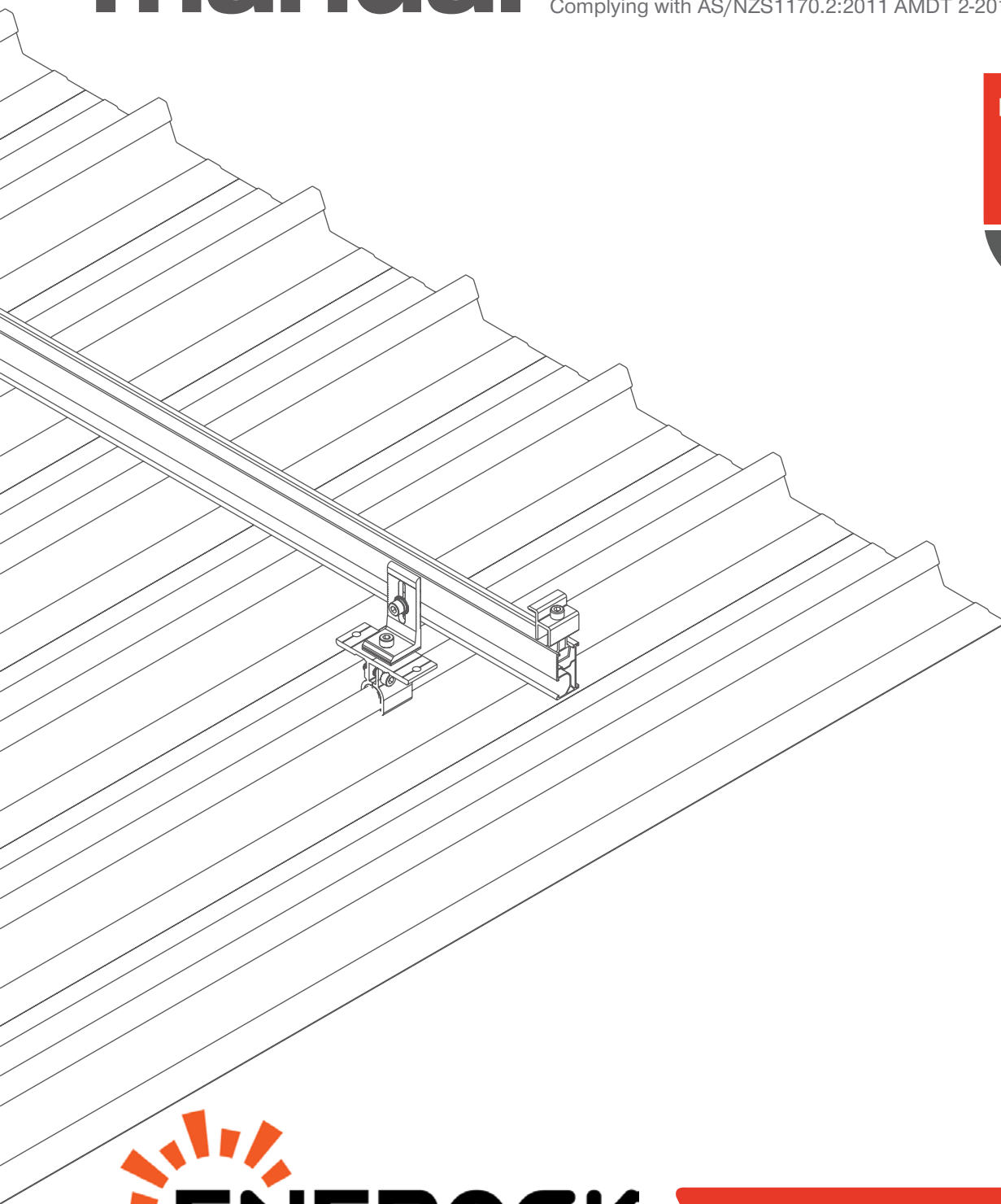

[www.enerack.com](http://www.enerack.com)

PUB  
NOV  
2019

> Disclaimer .....	1
> Rail Mount Components List .....	2
> Assembly & Sectional Drawing .....	3
> Preparing .....	4-5
> Kilp-lok clamp spacing chart .....	6
> Pv Array Layout & Location .....	7
> Installation .....	8-12
> Grounding Components & Electrical Diagram .....	13
> Warranty .....	14

## Disclaimer

This manual describes the proper installation procedures and provides minimum standard required for product reliability and warranty. Thoroughly understanding this manual is imperative to proper installation.

## Please review the following before installation

- Make sure the roof is in proper condition prior to installation.  
Do not install on damage roofs.
- Comply with roofing manufacturer’s warranty terms.
- Ensure your work comply with local building codes and requirements, include any that may supersede this manual
- Ensure all products are appropriate for the installation, environments, and array under the site’s loading conditions.
- Ensure the installation is performed by licensed contractors, ` electrical installation must be conducted by licensed electrician. Ensure all work comply with local requirements.
- Use system components supplied by Enerack or parts recommended by Enerack.



This manual does not list all precautions needed for safe work. The installation must comply with health and safety requirements and other relevant standards and codes of practice. The manual provides guidelines for installation, but it does not guarantee the quality of installation work. Please complete the installation in a responsible and professional manner.

## TOOLS AND TORQUE VALUE

### Installation tools

- > 6 mm Allen key or hex driver bit
- > Cordless-driver (non-impact)

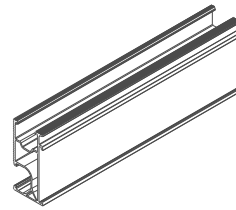

**Rail**  
**Material:** Aluminum extrusion, AL 6005 T5  
**Finish:** Clear or black anodized

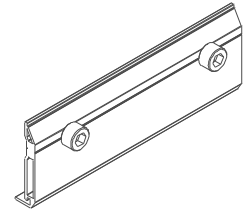

**Rail splice**  
**Material:** Aluminum extrusion, 6005 T5  
**Finish:** Clear or black anodized

### torque value

- > Rail splice: 8 N·m
- > Clamp screw: 16 N·m
- > L foot to clamp : 16 N·m
- > L foot to rail: 16 N·m
- > Mid clamp: 10 N·m
- > End clamp: 10 N·m
- > Grounding lug to rail: 8 N·m
- > Grounding lug for copper: 3 N·m

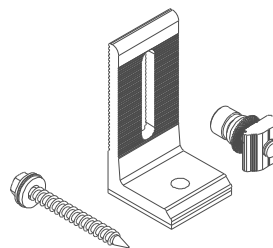

**L foot**  
**Material:** Aluminum extrusion, AL 6005 T5  
**Finish:** Clear anodized

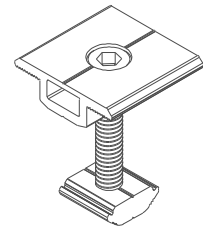

**Universal mid clamp**  
**Material:** Aluminum extrusion, 6005 T5  
**Finish:** Clear or black anodized  
**Frame size:** 30/40mm

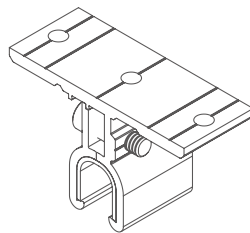

**Klip-lok 406 clamp**  
**Material:** Aluminum 6005 T5  
**Finish:** Anodized

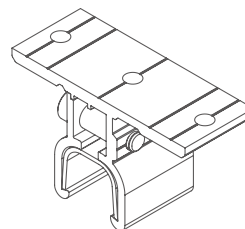

**Klip-lok 700 clamp**  
**Material:** Aluminum 6005 T5  
**Finish:** Anodized

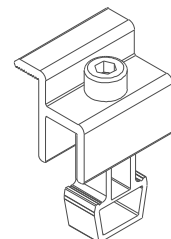

**Universal end clamp**  
**Material:** Aluminum extrusion, 6005 T5  
**Finish:** Clear or black anodized  
**Frame size:** 30/40mm

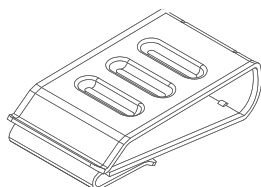

**Cable clip**  
**Material:** stainless steel 304  
 For 4 x PV cables 4mm<sup>2</sup>

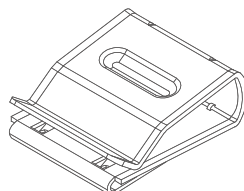

**Cable clip**  
**Material:** stainless steel 304  
 For 2 x PV cables 4mm<sup>2</sup>

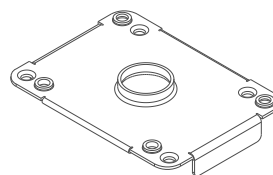

**Grounding clip**  
**Material:** stainless steel 304

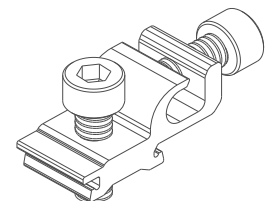

**Grounding lug**  
**Material:** stainless steel 304

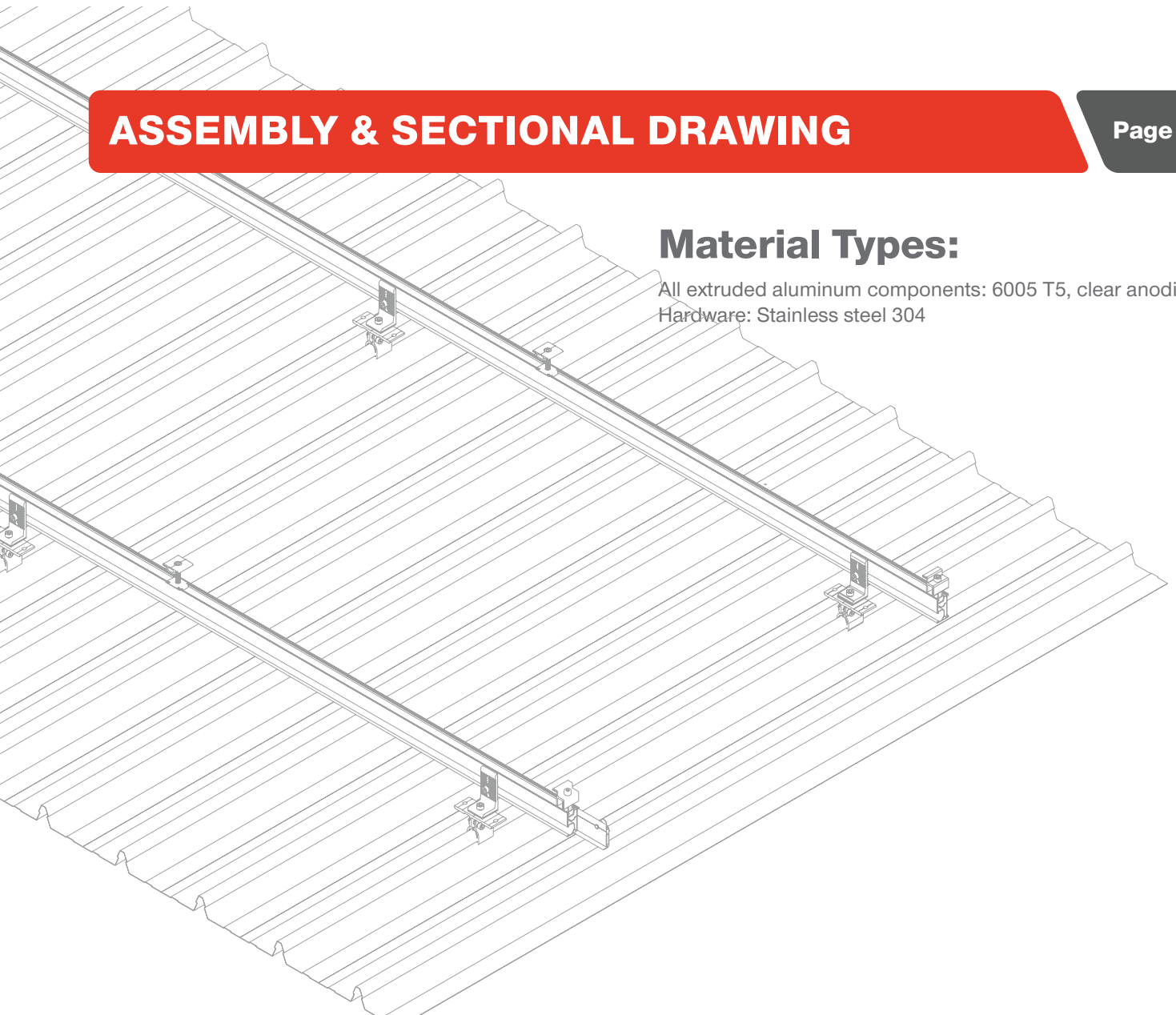

## Material Types:

All extruded aluminum components: 6005 T5, clear anodized  
Hardware: Stainless steel 304

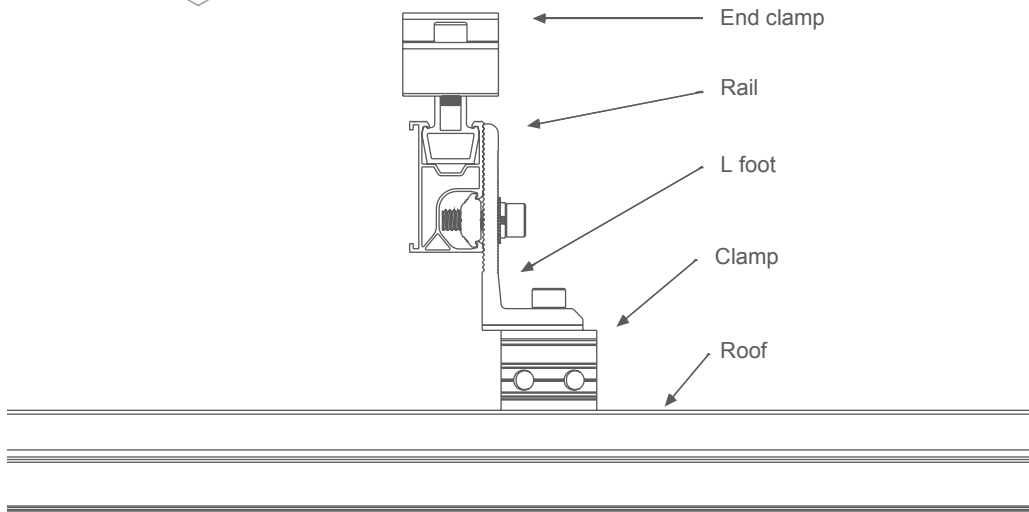

- Determine the max wind speed region of your installation site

Wind zone	A	B	C	D
Max wind speedm/s	43	56	66	88

- Determine the Terrain Category

## Terrain Category 2 (TC2)

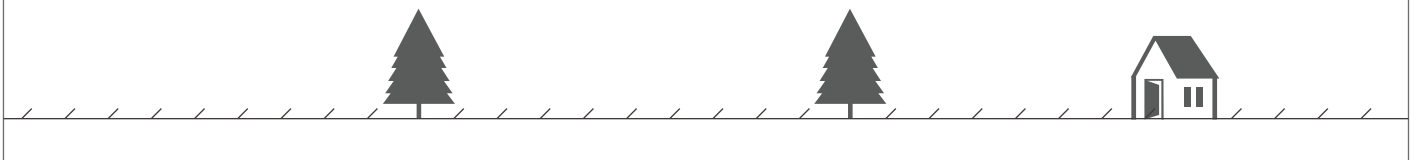

### Terrain Category 2 (TC2)

Open terrain, including grassland, with well scattered obstructions having heights generally from 1.5m to 5m, with no more than two obstructions per hectare, e.g. farmland and cleared subdivisions with isolated trees and uncut grass.

## Terrain Category 3 (TC3)



### Terrain Category 3 (TC3)

Terrain with numerous closely spaced obstruction having heights generally from 3m to 10m. The minimum density of obstructions shall be at least the equivalent of 10 house sizes obstructions per hectare, e.g. suburban housing or light industrial estates.

- **Determine the height of building**

Note: This manual is for installation in building height  $\leq 20$  meters

- **Determine Roof slope**

Note: The installation manual is for roof slope up to 30 degrees.

- **Determine Roof zone.**

The roof zone describes the amount of the wind load that is subjected to the roof. Internal zone has the lowest load, the mounting system are designed to be installed to the internal zone. The installation is recommended to be over the internal zone as much as possible.

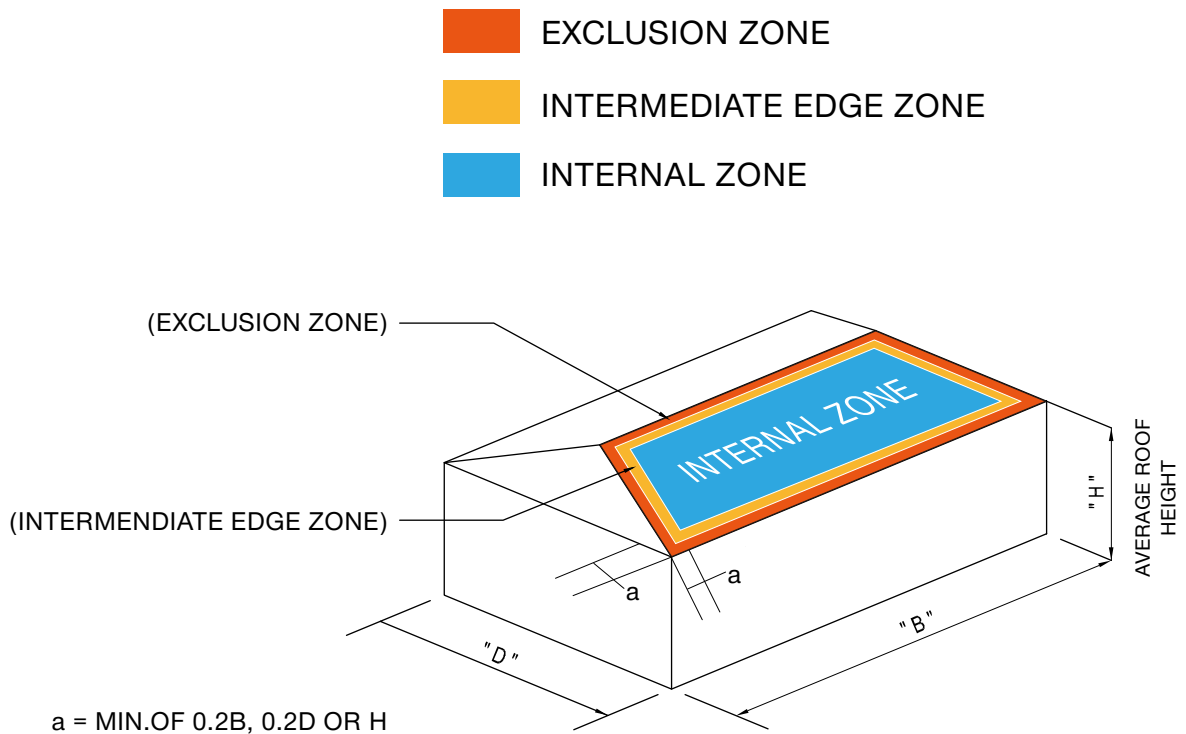

## ROOF REGIONS

Please use the following table to determine the Kilp-lok clamp spacing for installation.

## • Design code reference

The following engineering references were considered in determining the values of the wind load conditions and material properties of the aluminum rail.

- > AS/NZS 1170.2:2011 Admt 3-2012
- > AS 1664.1.1:1997 on aluminum structures

## • Design criteria

The following parameters were considered in determining the values of the allowable span charts of the railing.

- Wind region A,B, C, D
- WIND TERRAIN Category 3
- PV modules to be flush installed on the roof
- Max building height 20m
- Max roof slope: 30 degree
- Max PV module: 2000 x 1000mm

### Roof Angle( $\phi$ ) – $\phi < 0^\circ$

Wind zone	Building height H (m)		
	H≤10m	10<H≤15	15<H≤20
A	1570	1460	1370
B	1080	980	920
C	590	540	510
D	430	N/A	N/A

- > IBC 2015 / CALIFORNIA BUILDING CODE 2016
- > ASCE 7-10( wind loading)
- > Aluminum Design: Aluminum Design Manual 2010

### Roof Angle( $\phi$ ) – $0^\circ \leq \phi \leq 30^\circ$

Wind zone	Building height H (m)		
	H≤10m	10<H≤15	15<H≤20
A	1730	1640	1570
B	1270	1150	1080
C	820	590	560
D	530	500	440

- > Maximum Building Height Considered = 30ft
- > Exposure Categories Considered: B & C
- > Wind Pressure Based on Section 30.4 (C&C Method 1)
- > Gust Factor, G = 0.85
- > Topography Factor, Kzt = 1.0
- > Directionality Factor, Kd = 0.85
- > Importance Factor, I = 1.0
- > Maximum Cantilever of Railing from Anchor 12 Inches
- > Tilt Angles Considered: 0 to 30 degrees

Ground Snow Load (PSF)	Exposure B Wind Speed (Mph)						Exposure C Wind Speed (Mph)		
	110			130			150		
	110	130	150	110	130	150			
0	6	6	4	6	4	2			
10	6	6	4	6	4	2			
20	6	6	4	6	4	2			
30	6	6	4	6	4	2			
40	6	6	4	6	4	2			
50	6	6	4	6	4	2			
60	6	6	4	6	4	2			
70	4	6	4	4	4	2			
80	4	6	4	4	4	2			
90	2	6	4	2	2	2			

\* Maximum Building Height Considered = 30ft

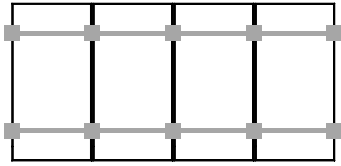

## PV array Length required

1. Total width of the modules
2. 17mm for each mid clamp
3. 20.5mm for each end clamp
4. 20mm for 1 grounding lug per row of module
5. 50-100mm extra length for any adjustment or other application.

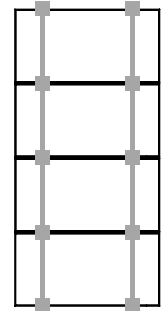

## PV array orientation

Each row of modules is held to the roof using rails which are to be fastened by a number of Klip-lok clamp and L foot connectors. The rails can be laid out parallel to seams or perpendicular to the seams.

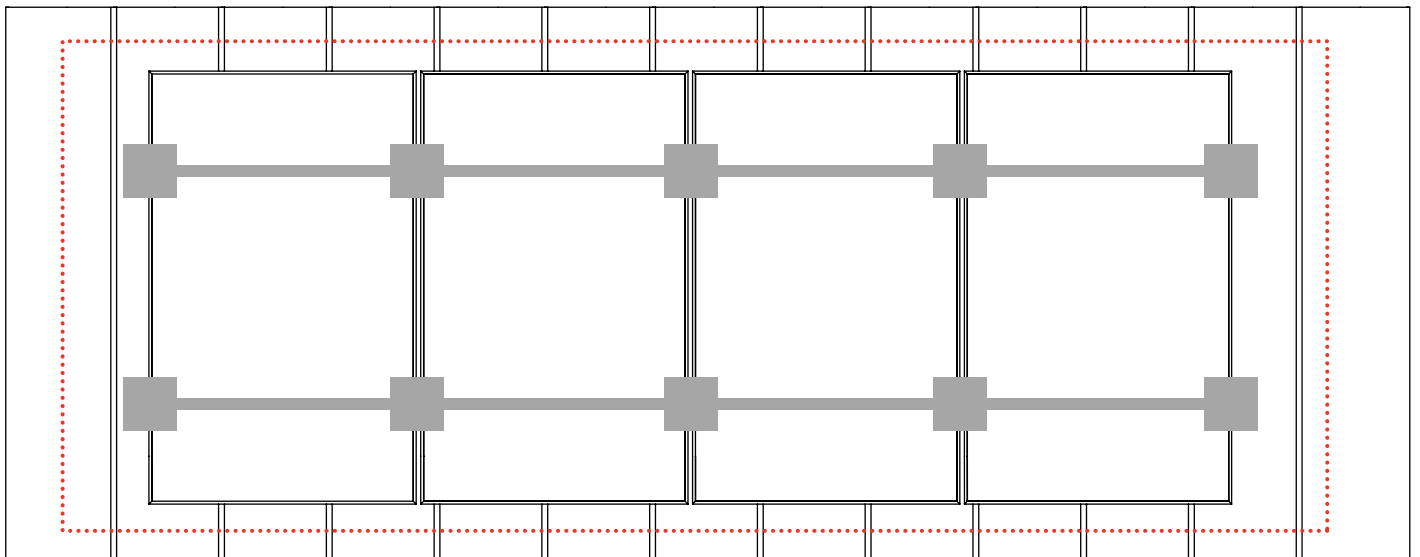

## PV array location

- Determine the appropriate installation area on the roof. Make sure the installation area to be center over the roof as much as possible.
- locate the row positions for Klip-lok clamp and mark them on the seams as outlined in your plans and engineering documents. Ensure they are in line with the each other.
- Locate each Klip-lok clamp on appropriate span and mark them on seams.



Note: the PV array should not be installed closer than 500mm to the perimeter of the roof including ridge line and eaves (unless verified by a professional engineer).



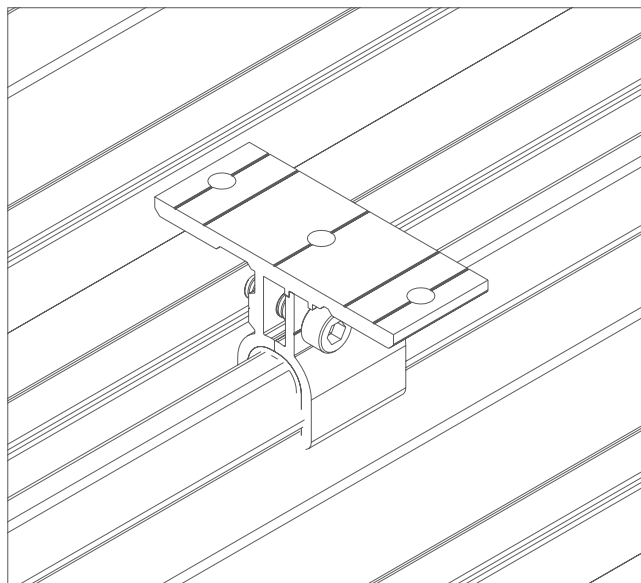
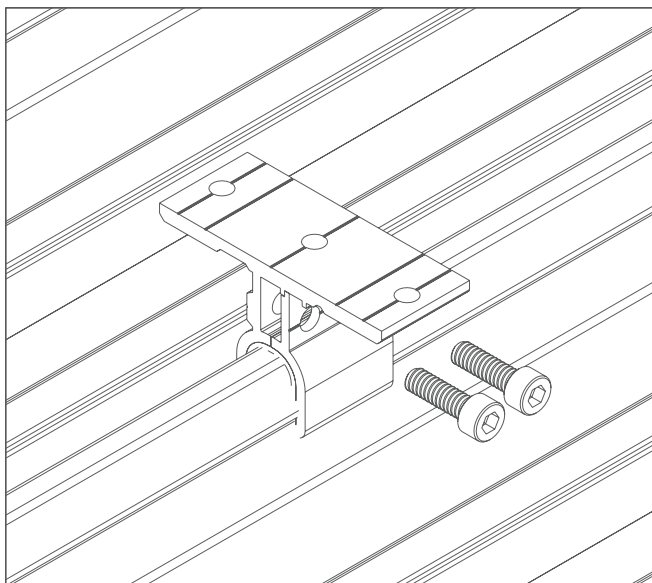

## Install standing seam clamps and rails

1. Attach the clamp and tighten the screw to 16 N.m using a 5mm Allen key or drill bit to roof per as planned plan position.

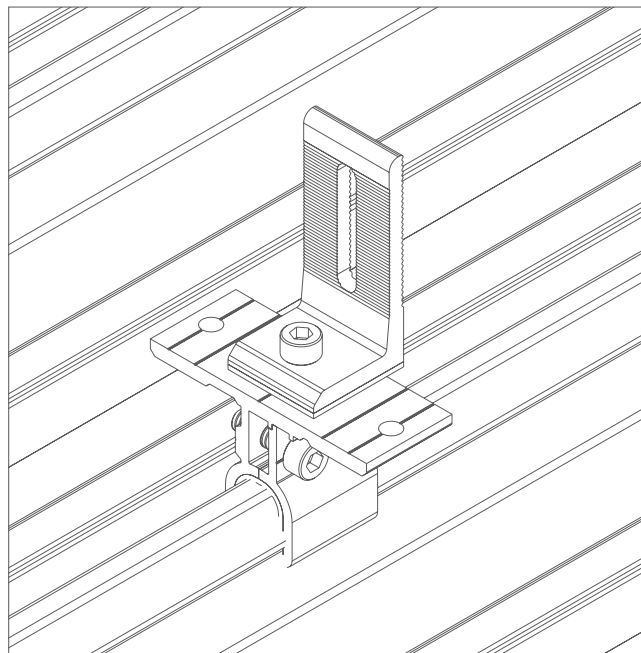
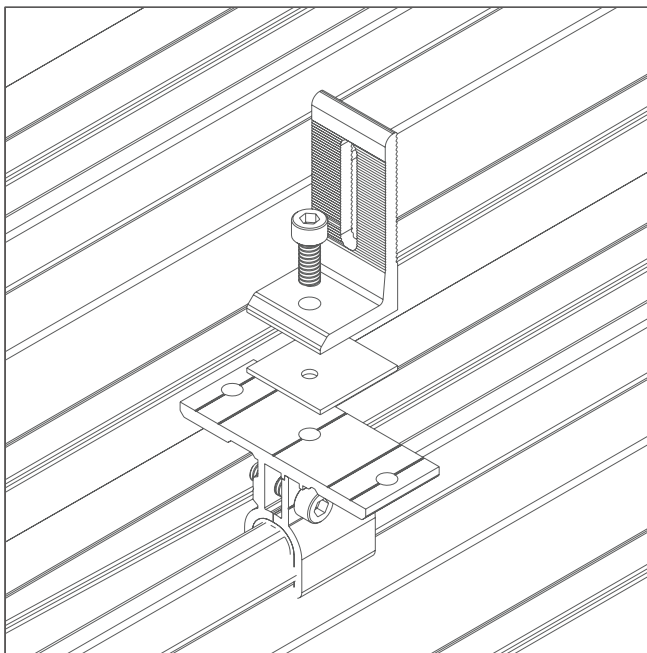

2. Tighten the L foot connector to clamp to 16 N.m using a 5mm Allen key or drill bit.

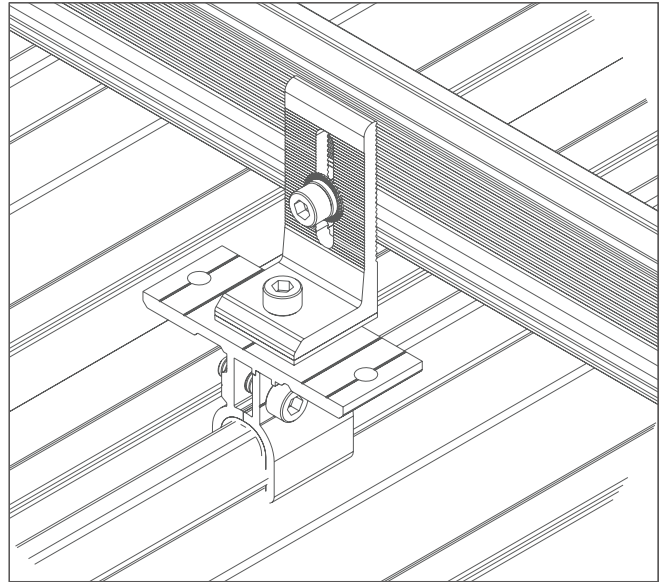
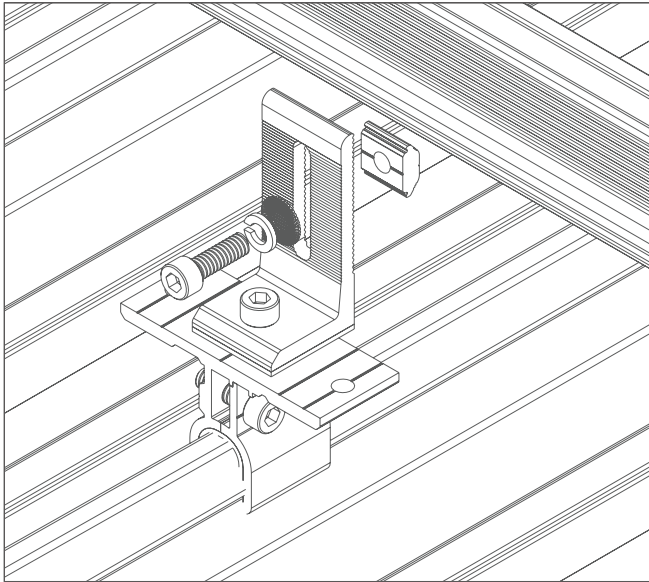

3. Connect rails to L foot to 16 N-m using a M6 Allen key or hex driver bit

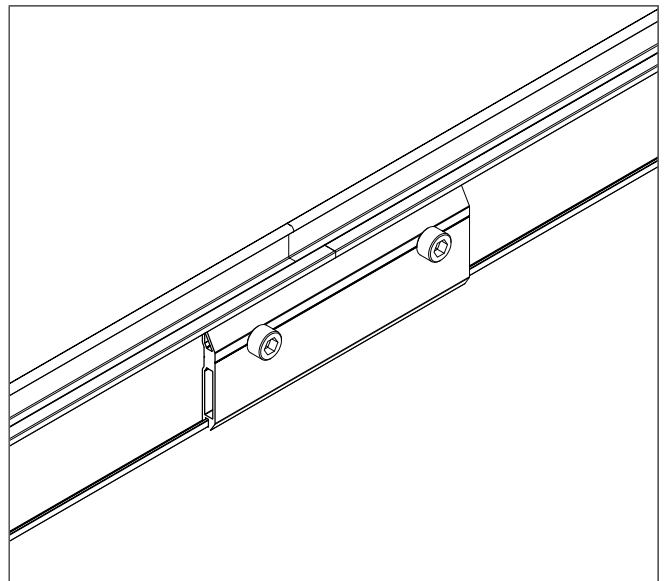
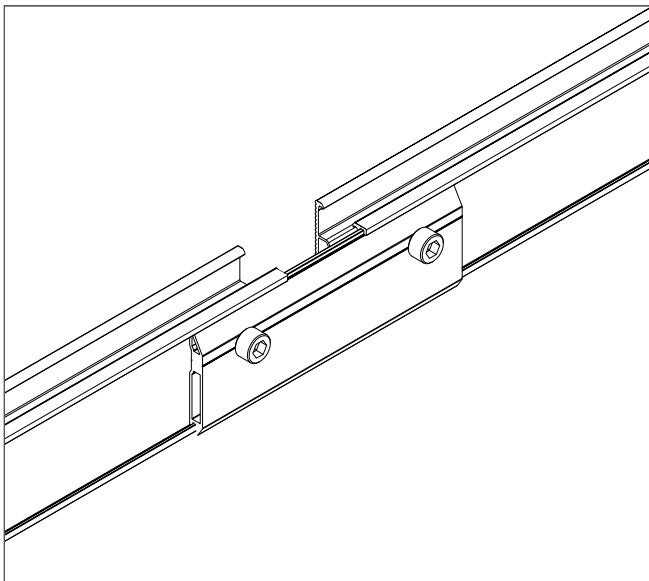

4. Connect multiple rails by using rail splice (if required per system design)

**Note:** Ensure the rails are square before placing modules

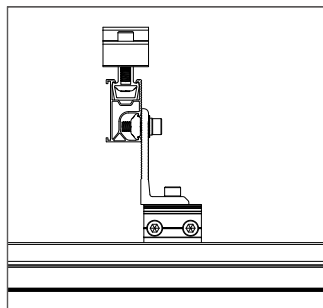
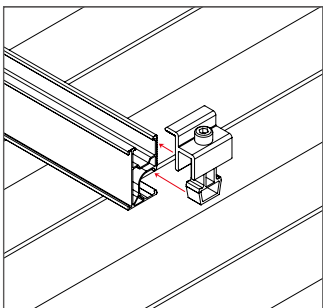
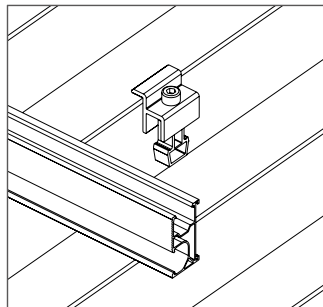
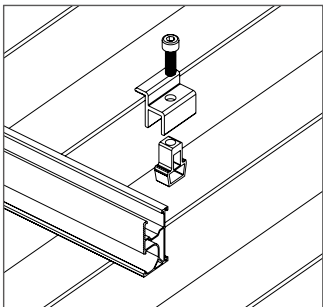
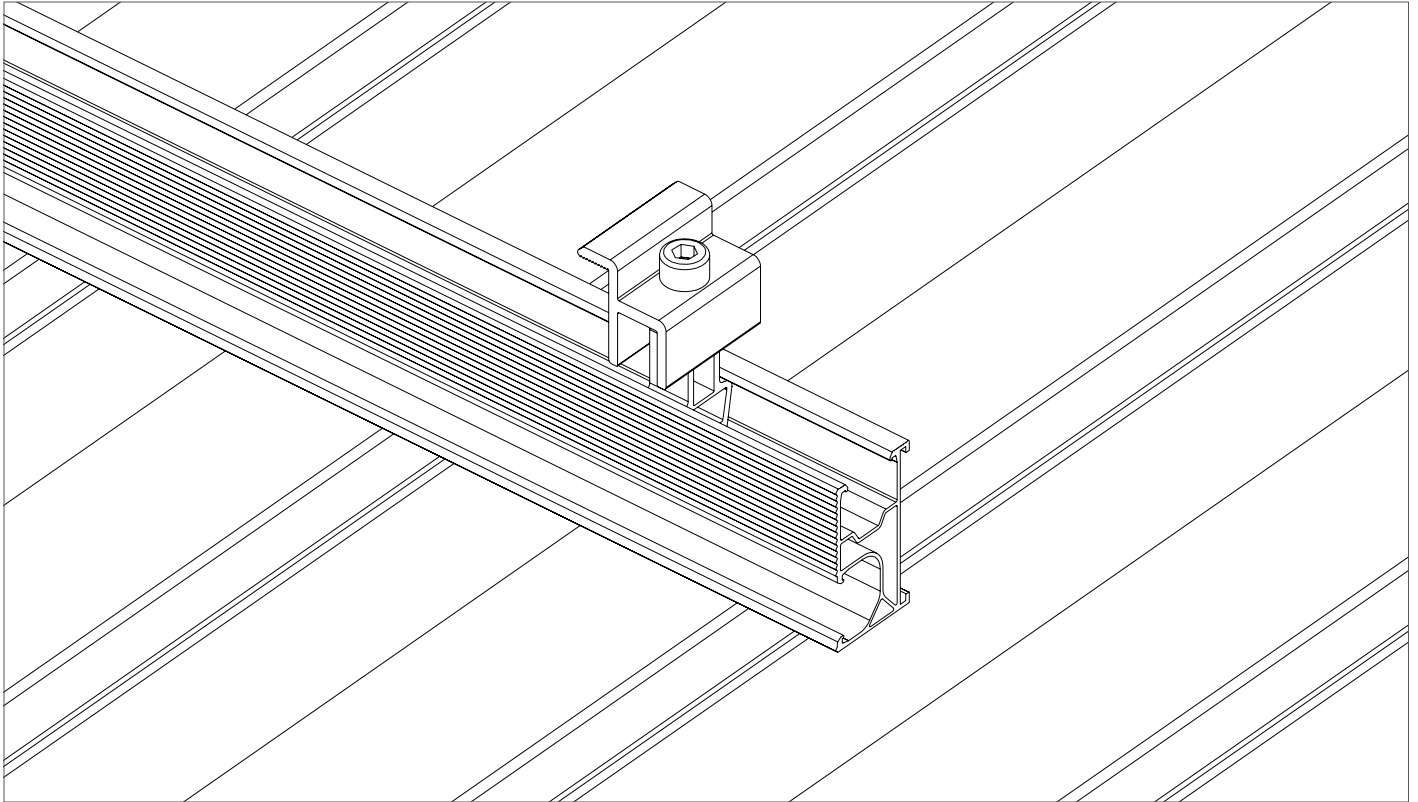

## Install the mid clamp and end clamp

1. Place the first PV module with a minimum 25mm from rail ends, slide end clamp into both rails and tighten the end clamp to 10 N·m using 6 mm Allen key or hex driver bit

### Note:

- Leave extra 25mm If grounding lug is to be installed at this end of rail
- Ensure the module length is align with the rails ends.

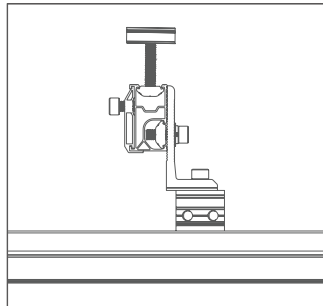
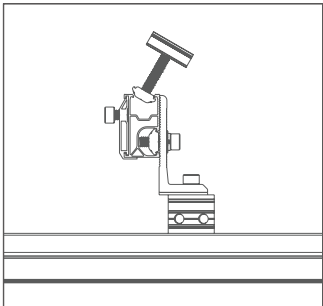
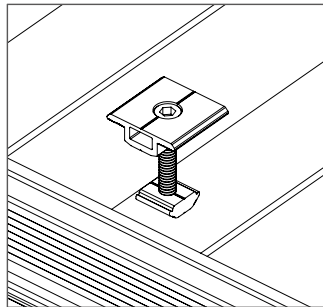
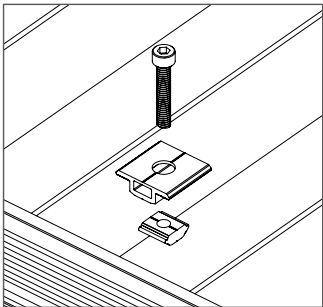
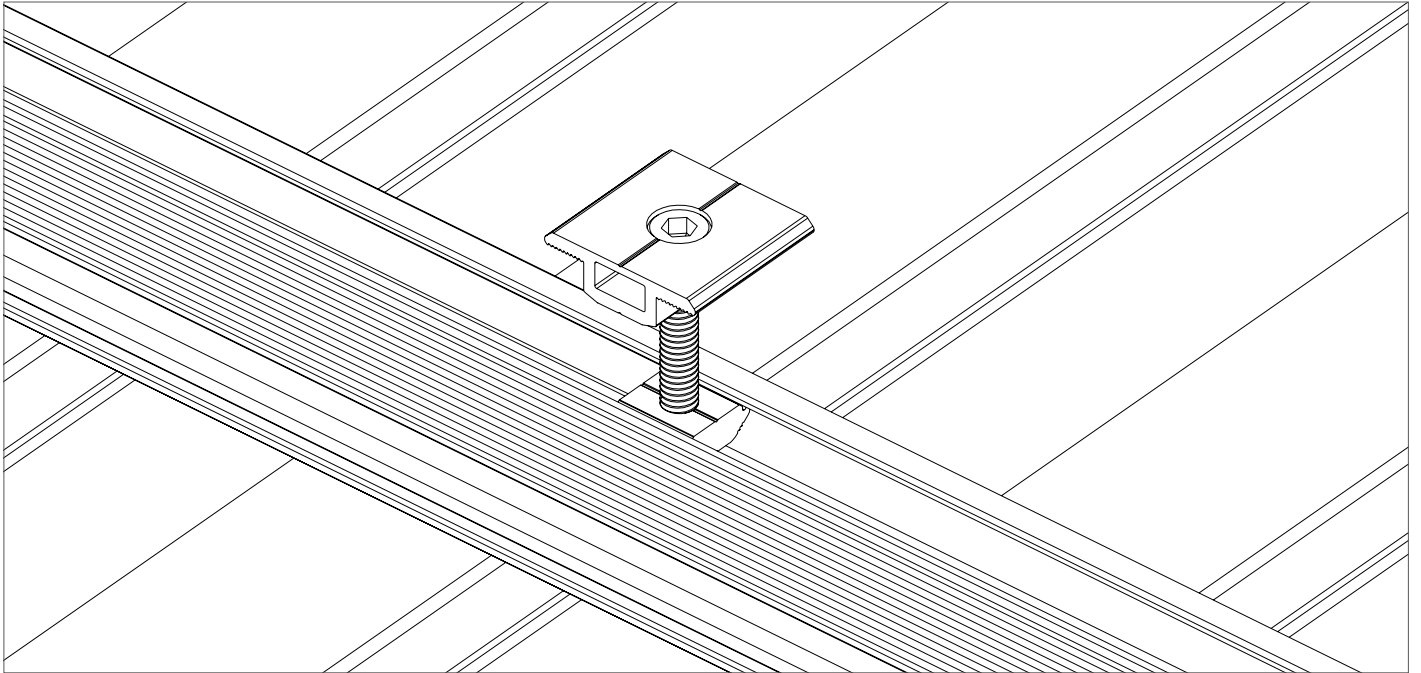

2. Place second PV module into rail, leaving a 20mm gap between modules and insert the mid clamps, slide the PV module flush against mid clamp closely, then tighten the mid clamp screw to 10 N-m using 6 mm Allen key or hex driver bit. Repeat procedure for follow mid clamps.

**Note:**

- Ensure the PV modules are neatly square to one another
- Ensure the array is straight,
- Ensure the mid clamp is secured tighten
- If a grounding clip is used, please insert the grounding clip properly to mid clamp and place the modules. Make sure PV modules are well contacted to the grounding clips before the mid clamps are tighten

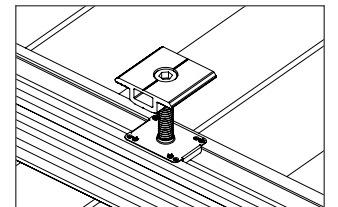
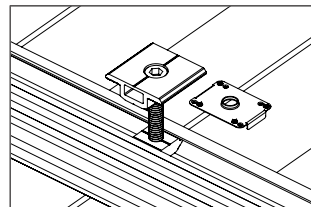

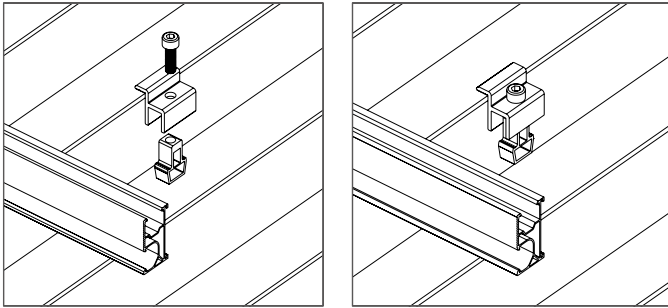

3. Place last module in position on rail with a minimal 50mm from rail end, slide end clamps onto both rails and tighten the screws to secure the PV module.

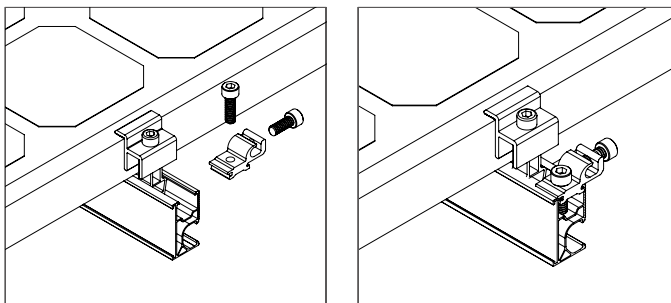
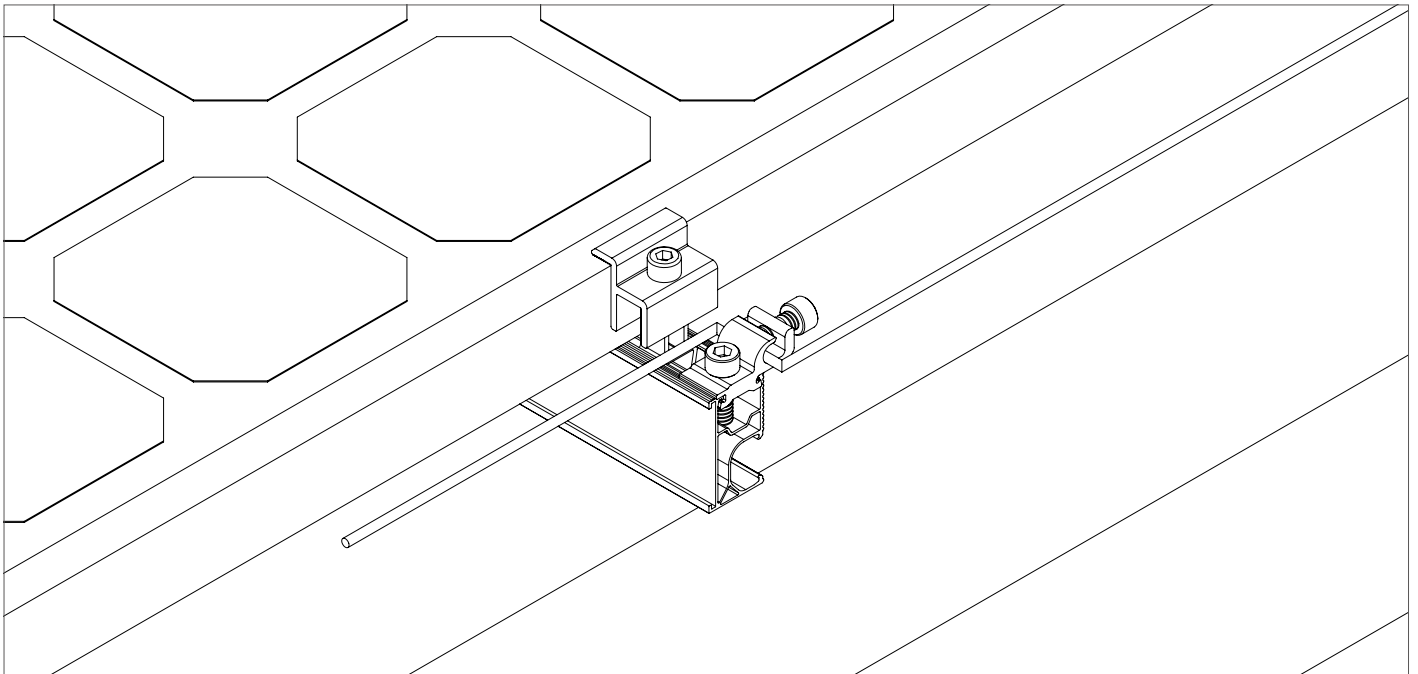

### Install the grounding lug.

Install the grounding lug to 8 N-m using 6 mm Allen key or hex driver bit at the end of a rail. Run grounding wire to connect all grounding lugs.

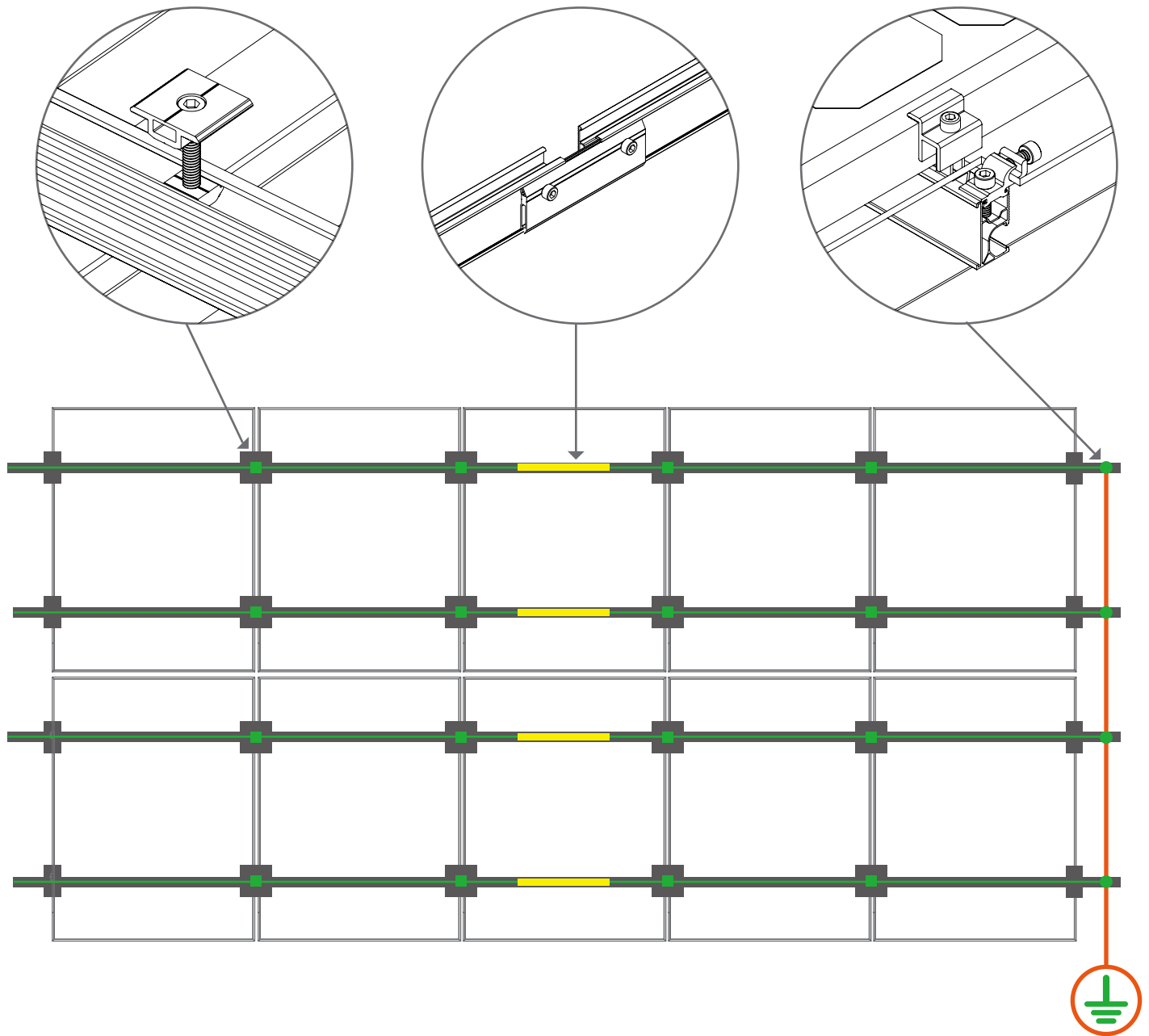

- Solar Module
- Mid Clamp
- End Clamp
- Ground Path
- Ground Lug
- Ground Clip
- Rail splice Kit
- Copper Wire

## 10 years limited product warranty, 5 years limited finish warranty

Xiamen Enerack Technology Co., Ltd("manufacturer") warrants to the original purchaser ("Purchaser") of product(s) that it manufactures ("Product") at the original installation site that the Product shall be free from defects in material and workmanship for a period of ten (10) years, except for the anodized finish, which finish shall be free from visible peeling, or cracking or chalking under normal atmospheric conditions for a period of ten five (10) years, from the earlier of 1) the date the installation of the Product is completed, or 2) 30 days after the purchase of the Product by the original Purchaser ("Finish Warranty").



The Finish Warranty does not apply to any foreign residue deposited on the finish. All installations in corrosive atmospheric conditions are excluded. The Finish Warranty is VOID if the practices specified by AAMA 609 & 610-02 – "Cleaning and Maintenance for Architecturally Finished Aluminum" ([www.aamanet.org](http://www.aamanet.org)) are not followed by Purchaser. This Warranty does not cover damage to the Product that occurs during its shipment, storage, or installation.

This Warranty shall be VOID if installation of the Product is not performed in accordance with Enerack's written installation instructions, or if the Product has been modified, repaired, or reworked in a manner not previously authorized by Enerack IN WRITING, or if the Product is installed in an environment for which it was not designed. Enerack shall not be liable for consequential, contingent or incidental damages arising out of the use of the Product by Purchaser under any circumstances.

If within the specified Warranty periods the Product shall be reasonably proven to be defective, then Enerack shall repair or replace the defective Product, or any part thereof, at Enerack's sole discretion. Such repair or replacement shall completely satisfy and discharge all of Enerack's liability with respect to this limited Warranty. Under no circumstances shall Enerack be liable for special, indirect or consequential damages arising out of or related to use by Purchaser of the Product.

Manufacturers of related items, such as solar modules and flashings, may provide written warranties of their own. Enerack's limited Warranty covers only its Product, and not any related items.